

Hand pallet truck 2.3 ton

BT lifter

L-series
LHM230



Hand pallet truck

Truck specifications					LHM230	LHM230U
Identification	1.1	Manufacturer			Toyota	Toyota
	1.2	Manufacturer's type designation			LHM230	LHM230U
	1.4	Operator type			Hand	Hand
	1.5	Load capacity/rated load	Q(t)	kg	2300	2300
	1.6	Load centre distance	c	mm	600	600
	1.8	Load distance, centre of drive axle to fork	x	mm	945 ¹⁾	945 ¹⁾
	1.9	Wheelbase	y	mm	1170 ¹⁾	1170 ¹⁾
Weight	2.1	Service weight		kg	63	63
	2.2	Axle load, with load, drive/castor/fork wheel		kg	375/805	375/805
	2.3	Axle load, without load, drive/castor/fork wheel		kg	20/10	20/10
Wheels	3.1	Steer/fork wheels: Powerthane (Po), Steel (S) Nylon (N), Polyurethane (P), Rubber (R), Rubber antistatic (Ra)			Po, S, N, P, R, Ra/ Po, S, N, P	Po, S, N, P, R, Ra/ N, P
	3.2	Wheel size, front			175x60	175x60
	3.3	Wheel size, rear			85x100 / 85x75 ²⁾	75x100 / 75x75 ²⁾
	3.5	Wheels, number front/rear (x=driven wheels)			2/2 or 2/4 ²⁾	2/2 or 2/4 ²⁾
	3.6	Track width, front	b ₁₀	mm	132	132
	3.7	Track width, rear	b ₁₁	mm	364	364
Dimensions	4.4	Lift	h ₃	mm	115	115
		Lift height	h ₂₃	mm	200	190
	4.9	Height of tiller in drive position, min./max.	h ₁₄	mm	1220	1220
	4.15	Height, lowered	h ₁₃	mm	85	75
	4.19	Overall length	l ₁	mm	1500	1500
	4.20	Length to face of forks	l ₂	mm	365	365
	4.21	Overall width	b ₁ /b ₂	mm	520/685 ³⁾	520/685 ³⁾
	4.22	Fork dimensions	s/e/l	mm	45/156/1150 ⁴⁾	45/156/1150 ⁴⁾
	4.25	Width over forks	b ₅	mm	520/685 ³⁾	520/685 ³⁾
	4.32	Ground clearance, centre of wheelbase	m ₂	mm	40	30
	4.33	Aisle width for pallets 1000 x 1200 crossways	A _{st}	mm	1525 ¹⁾	1525 ¹⁾
	4.34	Aisle width for pallets 800 x 1200 lengthways	A _{st}	mm	1725 ¹⁾	1725 ¹⁾
	4.35	Turning radius	W _a	mm	1370 ¹⁾	1370 ¹⁾

1) Distance with forks raised

2) Singel wheel / Boggie wheel

3) Other widths available on request

4) Other fork lenght available: 800/910/1000/1070/1220

All data are based on table configuration. Other configurations may give other values.

Truck performance and dimensions are nominal and subject to tolerances.

Toyota Material Handling products and specifications are subject to change without notice.

Dimensional drawings

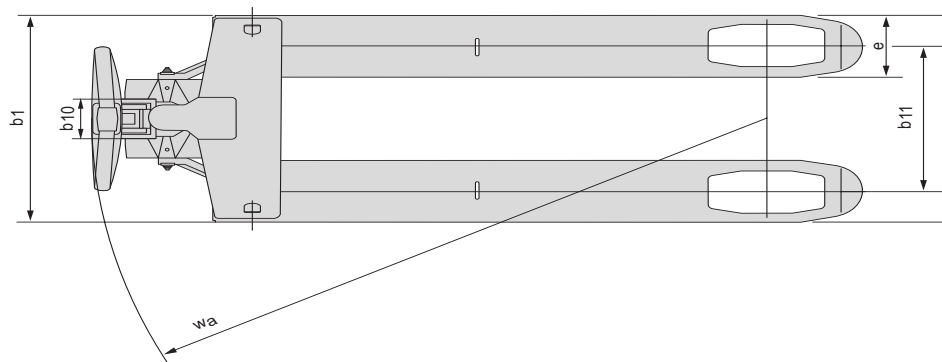
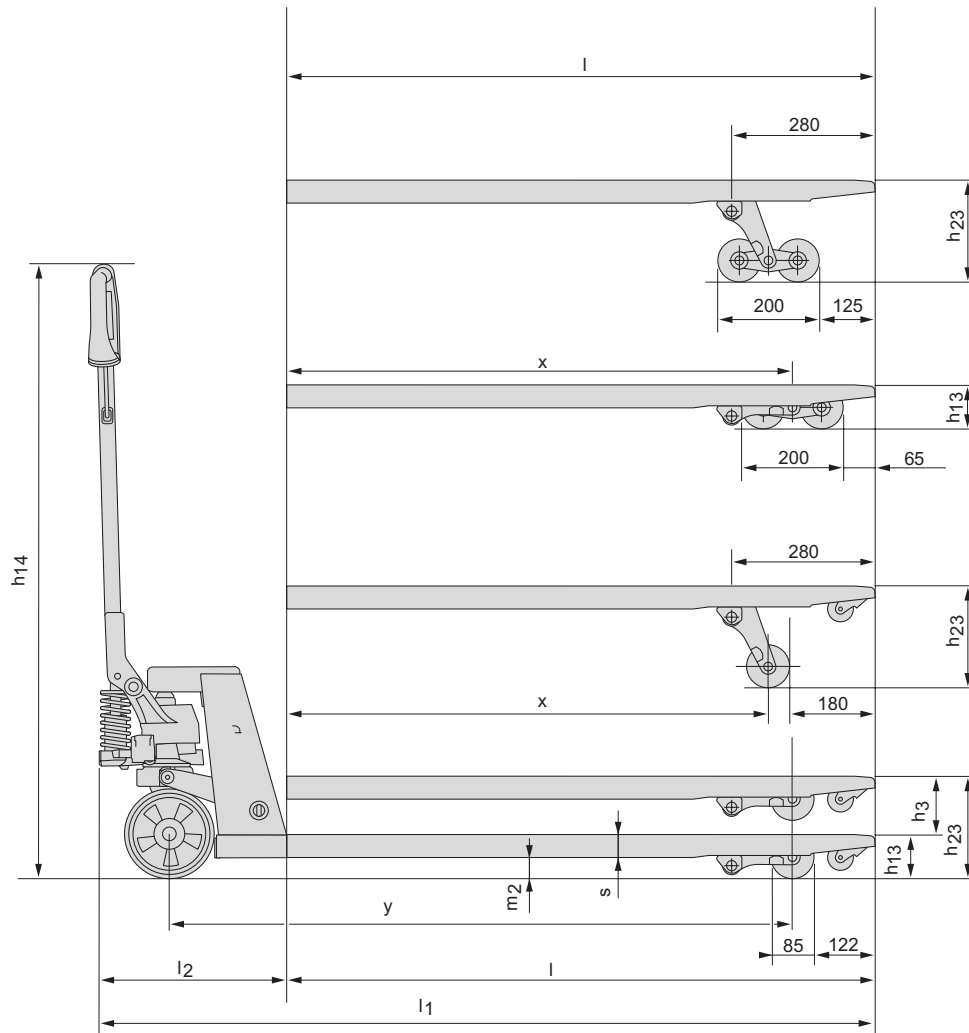

Truck features:

- BT's unique lifetime guarantee, gives the customer 99-years guarantee on the fork frame, valid for defects in materials and welding faults which can be derived from manufacturing. The guarantee on the pump unit and the tow bar is five years
- Robust design and still low weight – easy to manoeuvre
- Powder coating and robot welding give a high and even finish
- Angled high strength polymer handle for best ergonomic grip
- BT lowering control valve enables smooth, controlled lowering action
- Strong powerful thrust bearing is standard, for easier steering and enhanced durability
- Greasable bushings ensure long service life
- Quick lift and overload can be combined
- This product has been environmentally declared and is certified to ISO 14020, type II carrying the Toyota Industries Corporation's ECO label
- Customized configurations – a part of our offer



TMHE-Toyota Material Handling Europe – 745341-040, version 3, 2018-07-30

TOYOTA

MATERIAL HANDLING